



## Venue

The 2011 IEEE Region 5 Student Robotics Contest will be held concurrently with the regional conference in Baton Rouge, LA at the Hilton Capital Center on 201 Lafayette Street downtown. Student teams will be provided with tables, outlets, and practice space the day before and day of the competition.

## Contact and Online Information

For questions regarding the rules please e-mail Bryan Audiffred at [audiffred@ece.lsu.edu](mailto:audiffred@ece.lsu.edu). For all other matters related to the robotic competition please contact the chair, Bahadir Gunturk, at [bahadir@ece.lsu.edu](mailto:bahadir@ece.lsu.edu). Rules and forums will be hosted online.

## Revisions

6/29/2010	Initial Draft
8/18/2010	Preliminary Release
9/28/2010	Clarified telemetry and restrictions on using on-board power for flag. Labeled contacts on features. Fixed typo on 7805 regulator.
1/19/2011	Added dowel to end of wall Clarified time of placement for red source (page 6) Added dimension of starting circle Added some motor and capacitor testing Added schematics
2/4/2011	End of round condition #1 updated to specify the flag is raised AND the robot meets dimensions (page 6)
3/9/2011	Added endurance information for source batteries in the appendix and updated the round description to include testing of sources.

<b>Contestant Eligibility</b>	<b>3</b>
<b>Contest Description</b>	<b>3</b>
<b>Entry Requirements</b>	<b>3</b>
<b>Playing Surface</b>	<b>3</b>
<b>Objectives</b>	<b>4</b>
<b>Flag Information</b>	<b>5</b>
<b>Round Description</b>	<b>6</b>
<b>Scoring</b>	<b>6</b>
<b>Feature Design</b>	<b>7</b>
<b>Energy Sources</b>	<b>7</b>
<b>Flag</b>	<b>7</b>
<b>Compliance Monitoring</b>	<b>8</b>
<b>Questions to Consider</b>	<b>9</b>
<b>Appendix</b>	<b>10</b>
<b>RC Charging</b>	<b>10</b>
<b>Motor Performance</b>	<b>13</b>
<b>Schematics</b>	<b>14</b>
<b>Energy Source Endurance and Quality Assurance</b>	<b>15</b>
<b>Testing Procedure</b>	<b>15</b>

## Contestant Eligibility

The competition is open to all undergraduate students attending IEEE Region 5 educational institutions. Contestants are required to register appropriately for the regional conference and student activities.

## Contest Description

This year's contest will preserve the tradition of compact mobile robots operating on a predefined playing field. The challenge will be tiered to accommodate a broad range of skills and budgets.

The challenge will showcase renewable energy sources, each of which may be harvested by the robot competitors. The competition will be won by the robot that harvests the most energy in the allotted timeframe.

## Entry Requirements

Contestants will be screened by a judge before each round of competition. Entries not meeting the requirements will be disqualified for the round. These requirements take into account the scope and spirit of previous challenges.

1. Entries must be fully autonomous and self contained. Human or remote computer intervention is prohibited during play. One way telemetry from the robot is permitted.
2. The maximum dimensions of the robot are 1'x1'x2' high. All entry components should fit within this bounding box at the start and end of competition.
3. Entries must be generally safe in the opinion of the judges. The possibility of the robot causing harm to persons or property will be the deciding factor. This precludes the storage of flammable gases or liquids.
4. Robots may not exceed a generous weight limit of 50 pounds.
5. An easily accessible "start/stop" button must be provided for the judges to initiate competition. This button must be distinct and separate from any other buttons.
6. A standard dual female banana receptacle (or dual binding posts with female receptacles) should be located atop the robot and wired directly to the energy storage mechanism. A shorting plug will be placed in the receptacle prior to competition to ensure the source is depleted.

## Playing Surface

To preserve local student branch investments the same basic playing surface will be used as in previous years. This is an 8'x8' surface constructed out of MDF or equivalent (two 4'x8' sheets). A quick repaint should bring previous teams up to date. The following table highlights the necessary paint.

Table 1: Paint Information

Primer	White Pigmented	Kilz	Kilz2 Latex
White	Flat White	Rust-Oleum	1990
Black	Flat Black	Rust-Oleum	7776

The surface will be marked as in figure 1 using 1 inch black painted lines. A wall modeled by a 1" wide by .5" tall strip of wood will be permanently affixed to the playing surface. The wall will be painted white. A vertical dowel 6" in height will be placed at the end of the wall to prevent robots from partially crossing the wall.

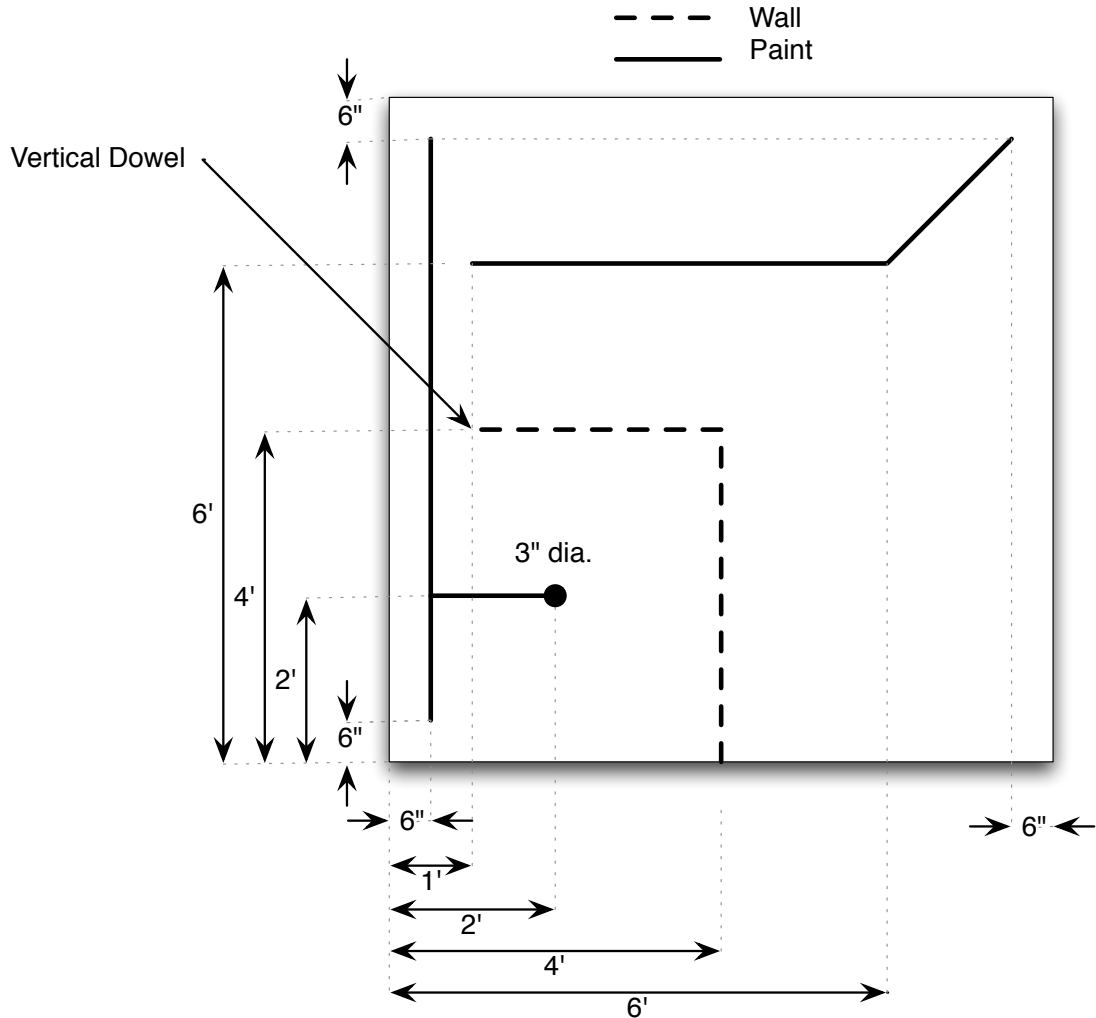

Figure 1: Bare Playing Surface

## Objectives

The course contains three renewable sources of energy modeled by a small cylinders with exposed metal contacts. Each provides a regulated voltage with differing output current capabilities. The least powerful source is the easiest to reach, and the most powerful source is the most difficult to locate. Competitors have a fixed amount of time to gather as much energy as possible and return to base to raise a flag as high as possible using the collected energy. The height of the flag and time will determine the winner.

**Only harvested energy may be used to raise the flag.** At no time may energy be transferred from internal batteries or other starting energy sources. This includes a direct or indirect transfer.

Figure 2 illustrates the locations of the energy sources. The capabilities of each source are listed below. The red energy source may be located anywhere in the lower right quadrant and at least 6" from the wall or edge of the field.

Table 2: Energy Sources

Source	Color	Thevenin Voltage	Thevenin Resistance
Solar	Blue	5V	120 Ohm
Windmill	Green	5V	68 Ohm
Hydroelectric	Red	5V	24 Ohm

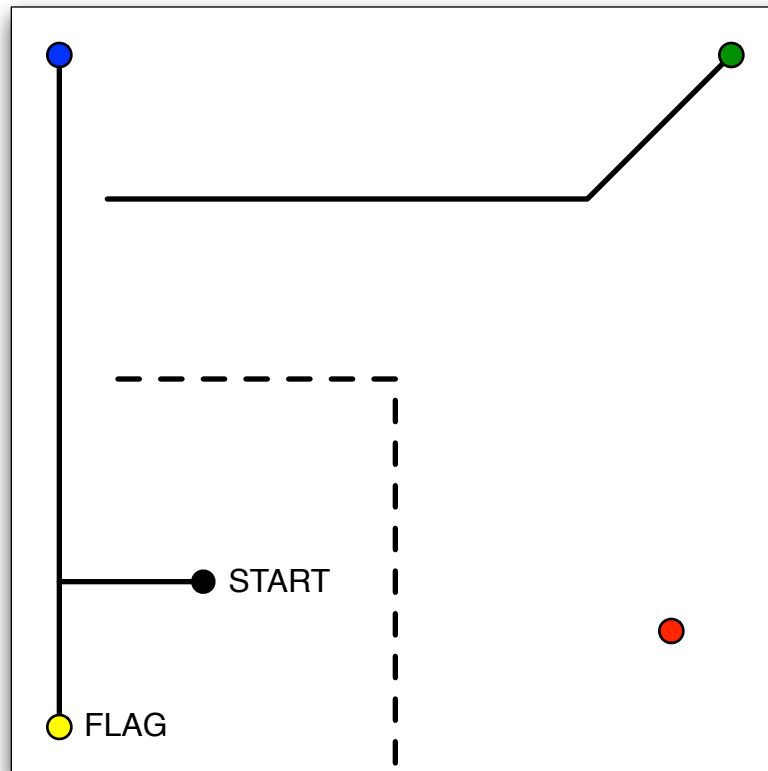

Figure 2: Illustrative Playing Surface  
*All objects are immobile*

### Flag Information

The flag is a simple mechanism designed to deliver an exciting and tangible visual indicator of work done. For simplicity's sake the assembly is actually a gear motor that raises and lowers a small block. The gear motor information is outlined in table 3. Further details may be found in the feature design section.

Table 3: Gear Motor Information

Voltage (nominal)	6V
RPM (output shaft)	45
Free running current	30mA
Stall current	360mA

## Round Description

There will be three rounds of competition, each identical. Teams must compete in the first or second round to qualify for the final round. Competition in both rounds is encouraged. The top five scores (may exceed 5 teams) will compete in the final round of competition. Rounds will proceed according to the following sequence of events:

1. The judge requests a team from the “on deck” area.
2. Students have 2 minutes to place their robot in the starting area and step back behind the predetermined team observation area. Part of the robot must cover the black circle marking the starting area. Any orientation is permissible.
3. A judge will remove the shorting plug and measure the voltage of the energy storage mechanism. The voltage must not exceed 10mV. A monitoring device will be inserted for the round.
4. The red source will be placed.
5. A judge will press the “start” button while another judge begins timekeeping.
6. The robot has 5 minutes of play to collect as much energy as possible and transfer it to the flag. Robots may use any of the sources and make as many trips as possible to and from the flag.
7. After 5 minutes, the height of the flag will be recorded. Teams may voluntarily end the round at any time with the prearranged signal. Any of the following will also end the round:
  - The flag reaches its maximum height and the robot meets the dimensional requirements (time will be noted)
  - The entirety of the robot leaves the playing field
  - The robot fails to move for 30 seconds and is NOT engaging in energy transfer activities. Transfer activity will be interpreted as being in electrical contact with the flag or energy source.
  - The robot crosses over a wall
8. Judges will verify the operation of any energy source used during the round.

## Scoring

Scoring is intentionally simple. There is no point system. Competitors are ranked on the amount of energy harvested and transferred via flag position. The reality of the competition is that not all teams will successfully harvest and transfer energy. In this case, competitors will be ranked via navigation to the energy sources in three discrete levels:

1. Touched the red source (maximum score)
2. Touched the green source
3. Touched the blue source (minimum score)

Teams that maximize the height of the flag will be ranked via completion time. Any team moving the flag will be ranked above teams that only navigate.

## Feature Design

The course features are very simple and offer opportunities for younger students to contribute to the team efforts.

## Energy Sources

The energy sources are simple regulated voltage supplies consisting of a battery, linear voltage regulator, and limiting resistor. The regulator is a very common part available in a student friendly TO-220 package.

Table 4: Energy Source Electrical

Battery	9V Alkaline
Linear Regulator	LM7805

The mechanical housing is a simple 3" PVC cap available at a hardware store. These conform to ASTM standard D2466 and are roughly 3.5" ID and 3.9" OD. The electrical contacts are 0.5" wide strips of thin sheet-metal. One way to make these is to buy inexpensive AC ducts and cut them to shape with shears. Electronics conveniently fit inside the cap. Contacts are located per figure 3. For robots using cameras and image recognition, the caps will be painted blue, green, and red using flat spray paint commonly available at hardware stores.

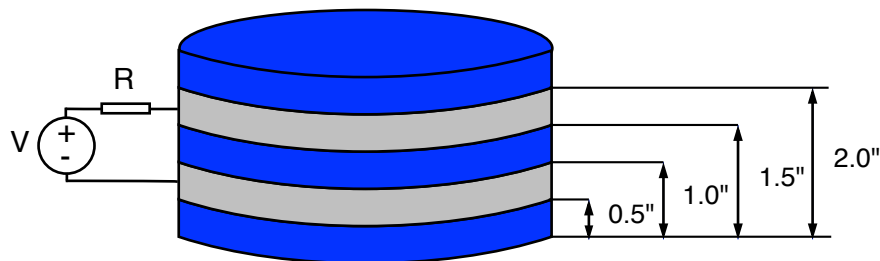

Figure 3: Energy Source

Energy sources will be semi-permanently affixed to the playing surface. They are not intended to move with normal contact. No guarantees will be made concerning heavy and fast robots crashing into them.

## Flag

The flag mechanism should be easy and cheap to reproduce while still providing a strong visual indicator to the audience of work done. Rather than "pushing" the flag up using a complex linear actuator, it will be hoisted with a drum and string. The gearmotor is a readily available component, and the rest of the assembly is non-critical to a team's mechanical fabrication skills.

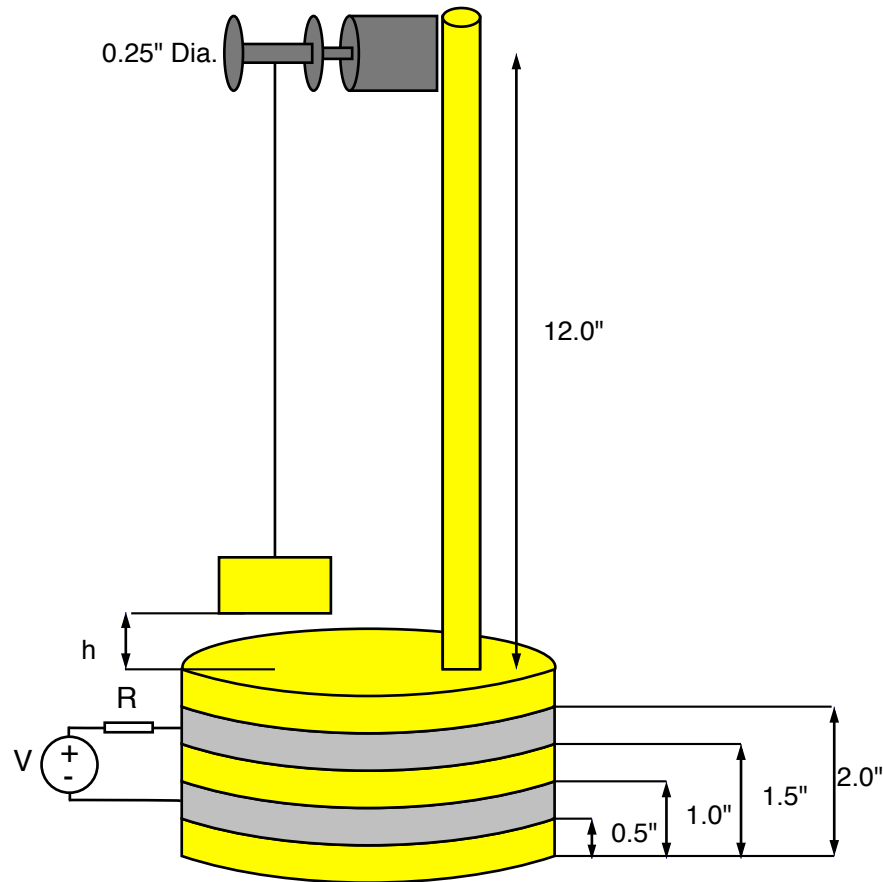

Figure 4: Flag Assembly

The gearmotor is part #1094 from Pololu Robotics at a cost of \$15.95. This particular motor was chosen for its low cost and low power. Should the part become unavailable by competition, an equivalent motor will be substituted.

The important point is that everyone will have the same load to power. To protect the motor from damage, a Zener diode in the neighborhood of 6V will be placed in parallel. **Teams should not design their electronics to exceed 5V at the motor.** The string will be very thin such that the impact of overlapping on the spool will not provide a tangible advantage in height. The flag presents a negligible load to the motor with such a high gear ratio.

### Compliance Monitoring

To ensure teams are not violating the spirit of the competition, the following safeguards will be in place:

1. Teams must produce current schematics on request of a judge. Entries failing to provide schematics will be disqualified.
2. Terminal access must be provided for the energy storage subsystem via dual banana jacks on top of the robot. This may be the capacitor connections or the generator terminals for a flywheel approach. A judge will verify negligible energy (via voltage measurement) is stored in the system at the beginning of each round.



3. During the round a small circuit and LED will be attached to the banana jack to monitor the voltage. It will flash to indicate changes in voltage. The circuit is self powered and presents a very large impedance to the robot.

### **Questions to Consider**

1. What is the maximum power that can be extracted from each source?
2. How does one extract the maximum power?
3. How long would it take to raise the flag?
4. How much power would it take to raise the flag?
5. For each source, how long would you need to collect energy to raise the flag one foot?
6. What is the cost and benefit of the harder to reach sources?

## Appendix

### RC Charging

Students have no doubt determined that the simplest (but not the best) way to gather and store energy is to connect a capacitor directly to an energy source. The following quick and dirty figures illustrate the performance of a 1F capacitor at each source. The X-axis scale is 180 seconds for each figure. Unfortunately LabView doesn't have an easy way to arbitrarily label the axes in this scenario.

You might expect 5 time constants to be 120 seconds, but the capacitor doesn't reach 99% of 5V in 180 seconds. In fact, hooking it directly up to a 5V bench-top supply won't charge it to 5V. Eventually the resistances in the supply and self discharge effects combine to stop any further gain in voltage. This particular capacitor was an Elna DBN-5R5D105T which seems to have a high self discharge rate.

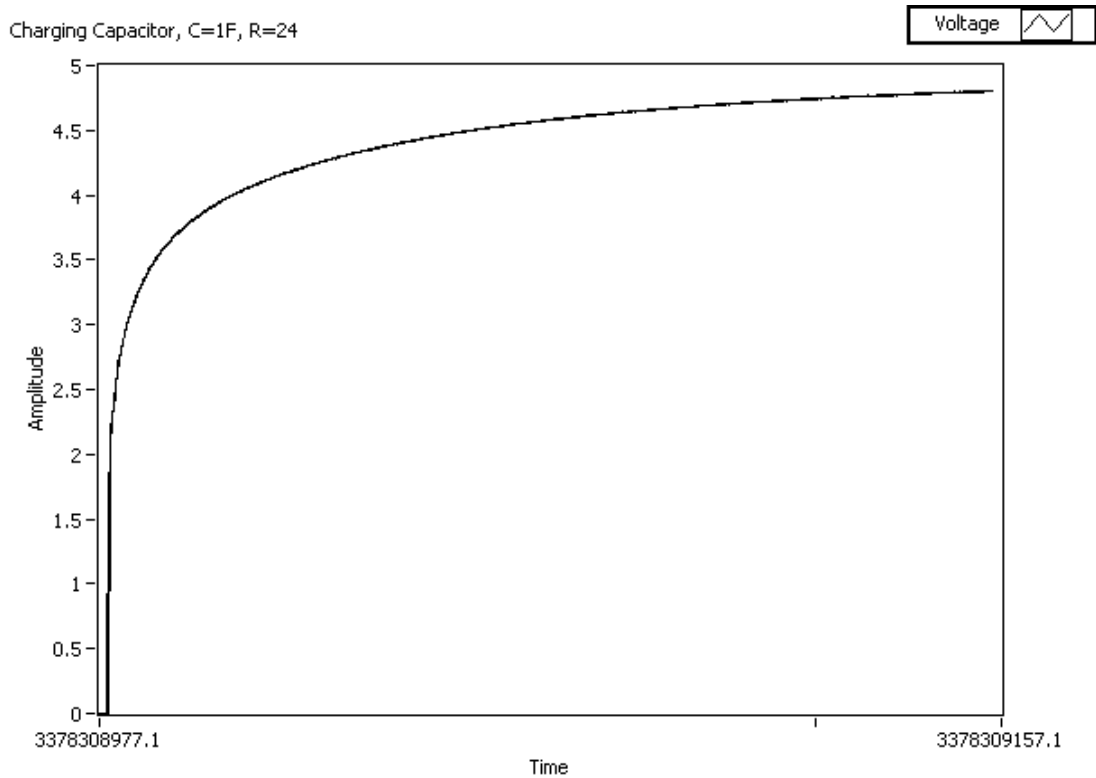

Figure A1: Charging Performance of Red Source (24 ohm) (180 sec)

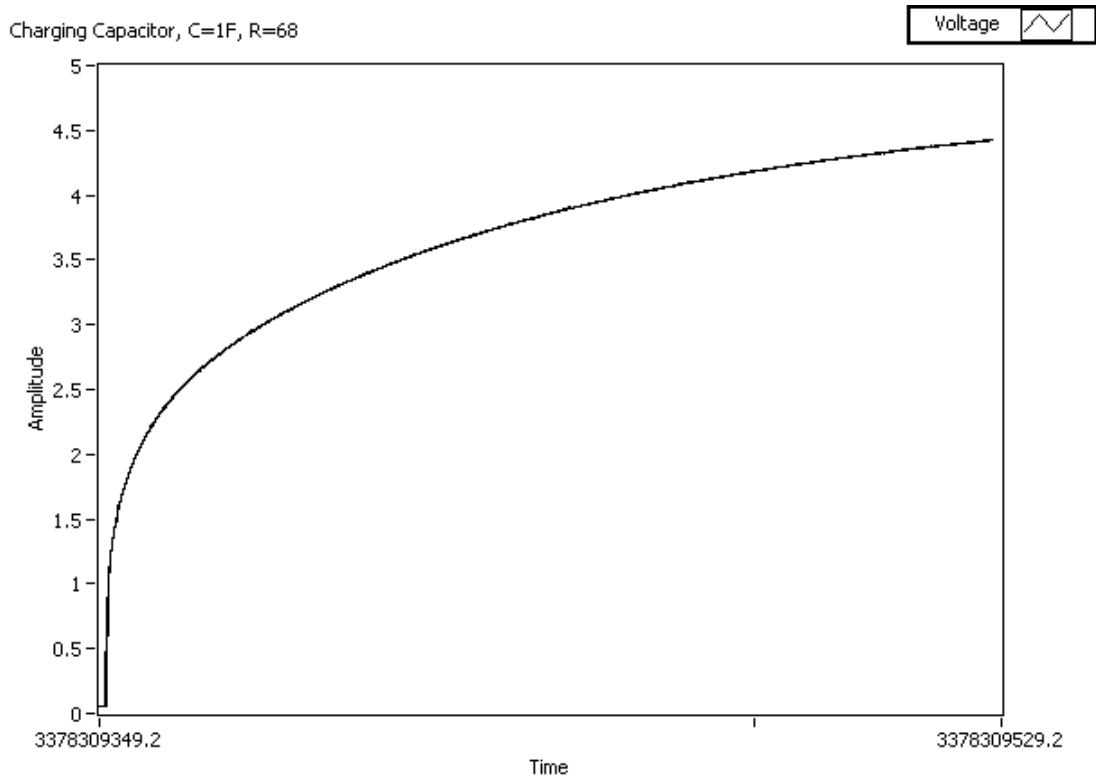

Figure A2: Charging Performance of Green Source (68 ohm)(180 sec)

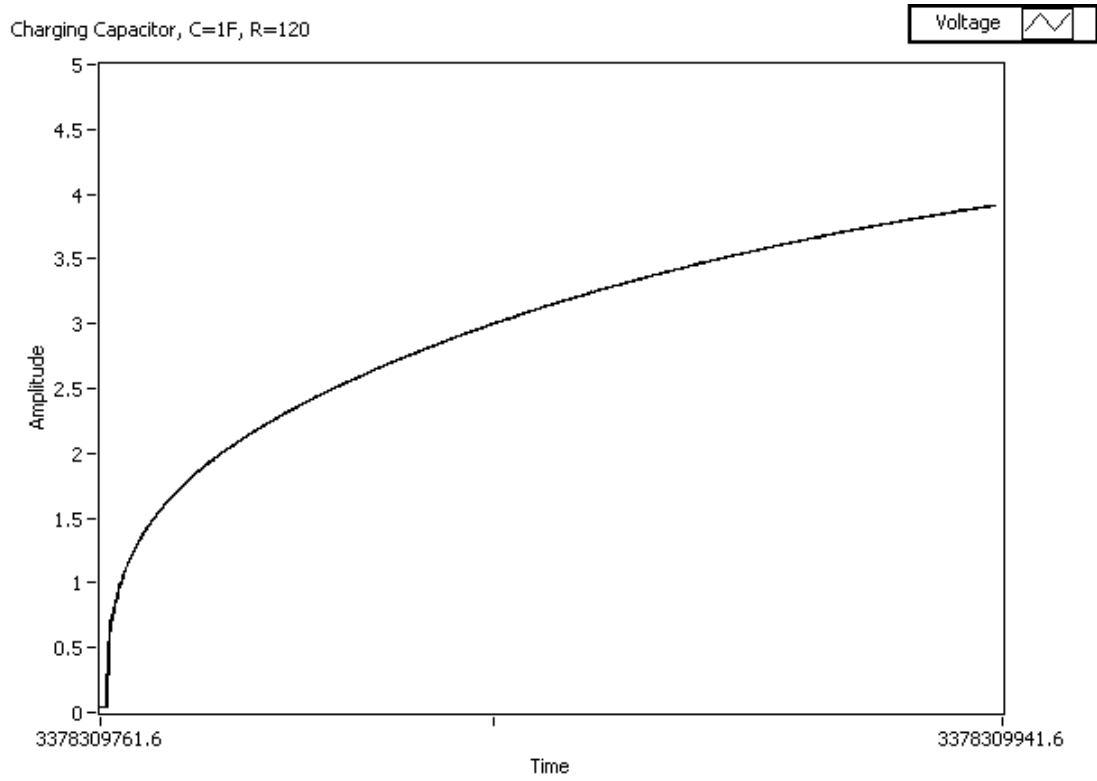

Figure A3: Charging Performance of Blue Source (120 ohm) (180 sec)

## Motor Performance

For those students who have not acquired the motor, a few bench-top experiments verified the no-load current to be around 25mA which reasonably concurs with the data sheet. As anticipated, the gearing is so low that the flag and drum will not appreciably load the motor. Best efforts to grasp and stop the output shaft failed. Motor current never exceeded 40mA.

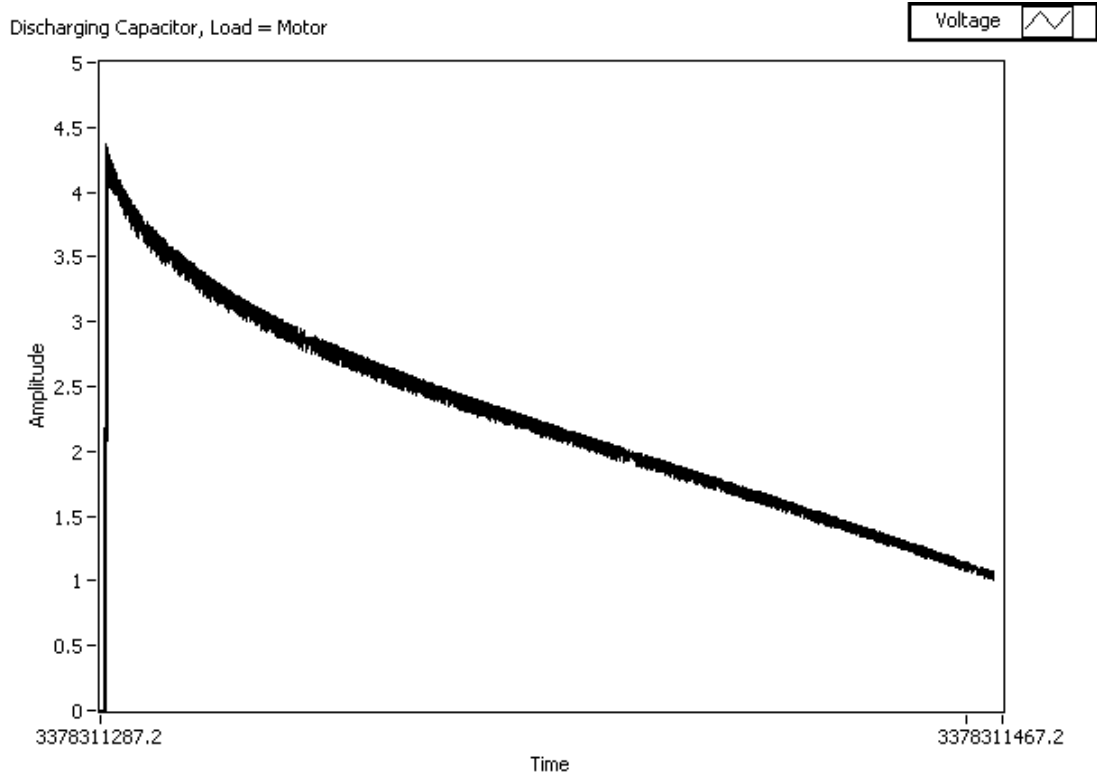
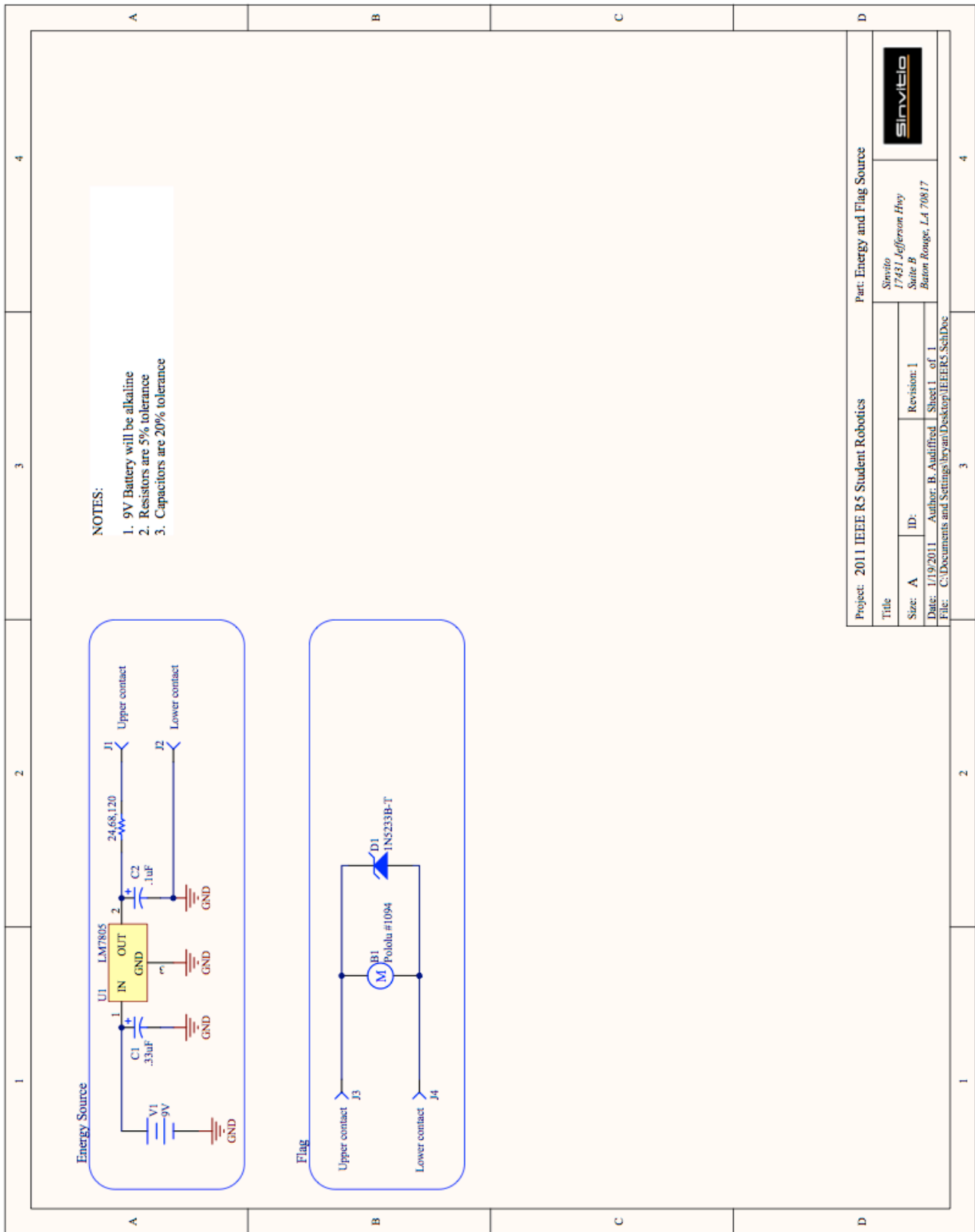

Figure A4: Capacitor Terminal Voltage - Discharge Into Pololu Motor (180 sec)

Figure A4 illustrates the 1F capacitor powering the motor directly from an initial charge near 4.5V. It is up to the students to determine the RPM corresponding to motor's terminal voltage. The motor ran for 180 seconds. Did it turn enough to raise the flag 12"?

Schematics



## Energy Source Endurance and Quality Assurance

It is vital that each team receive the specified voltage and current capacity from the sources. The dropout voltage of the regulators is 2V. The 9V primary cell will need to maintain at least 7V under load to maintain the 5V regulated output.

The capacity of a typical 9V battery is heavily dependent on the load current. For purposes of calculations we will consider a 9V Duracell Coppertop #MN1604. The 1W rating for the battery is 250mAH when discharged to 7V. The worst case is a shorted red source at 208mA and 1.04W. This would provide 1.2 hours of operation, or in the context of the competition, over 14 rounds of a competitor shorting the red source. This is highly unlikely.

*Lab tests verify a fresh 9V provides 80 minutes short circuit operation for a red source.*

The other source of power consumption is the quiescent current drawn by the regulator. This is typically 5mA (closer to 3mA in lab measurements). The lasting power of the battery in this case is well over 100 hours.

It is unlikely that the batteries will ever require changing throughout the competition, however it is still necessary to verify the function of the sources for each run.

### Testing Procedure

1. Judges will verify the operation of the energy sources before each round of competition by measuring their voltage and short circuit current capability.
2. After each run, judges will re-verify any energy source used by measuring the short circuit current. If the source fails to generate the expected current, it will be deemed faulty for the prior run, and the team will be permitted to repeat the run if they choose. Allowances will be made to permit battery replacement for the robot, but teams will not be able to make hardware or software changes.